

ALIGN THE RIP FENCE

65. Place the rip fence on the worktable by first putting the fence base on the front tube, as demonstrated in Figure B-87, then lowering the rest of the rip fence.

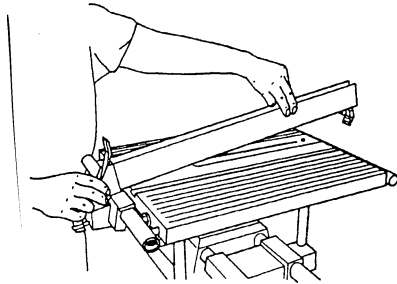

Figure B-87

66. Use a 5/32" Allen wrench to back out the adjusting set screw from the fence base so it doesn't contact the infeed table tube, as shown in Figure B-88.

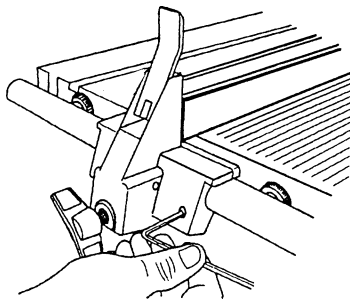

Figure B-88

67. Check to see if the fence rest fully contacts the outfeed table tube, as shown in Figure B-89.

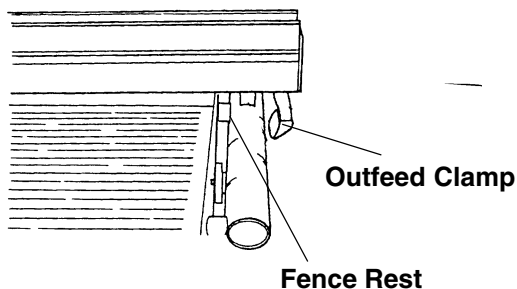

Figure B-89

68. If it doesn't, adjust the fence rest by doing the following:

- a. Raise the outfeed end of the rip fence and use a medium screwdriver to loosen the

two screws attaching the fence rest. Tighten the fence rest just enough to move it with firm pressure. See Figure B-90.

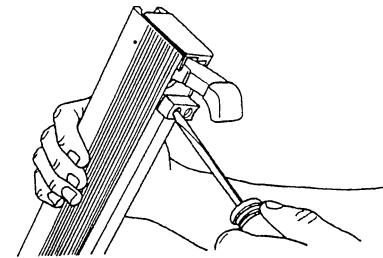

Figure B-90

- b. Place the rip fence back on the table and lock the handle.
- c. Use your fingers to adjust the fence rest until it fully contacts the outfeed table tube.
- d. Unlock the handle and carefully raise the fence. Use the medium screwdriver to tighten the fence rest's screws.
- e. Re-check the fence rest setting by remounting the rip fence on the worktable. If further adjustments are needed, repeat Steps a through d.

ADJUST THE OUTFEED CLAMP

69. Place the rip fence base on the infeed table tube, then lower the rip fence onto the outfeed tube. The outfeed clamp should just miss the table tube as it is lowered into place.

70. Lock both the base lock and the handle. See Figure B-91.

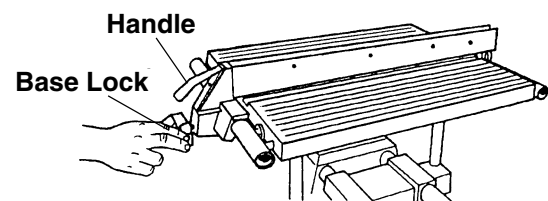

Figure B-91

71. If the clamp is too **tight** (hits the table tube), or too **loose** (allows slippage while it is locked), it needs adjusting. To adjust the outfeed clamp, do the following:

- a. If too **tight**, raise the handle, then use a 1/2" socket and ratchet wrench to loosen the

lock nut (217). When the clamp touches the table tube, loosen the lock nut 1/8 turn or less. See Figure B-92.

- b. If too **loose**, lock the handle, then use a 1/2" socket and ratchet wrench to tighten the lock nut (217). When the clamp touches the table tube, loosen the lock nut 1/8 turn or less. See Figure B-92.

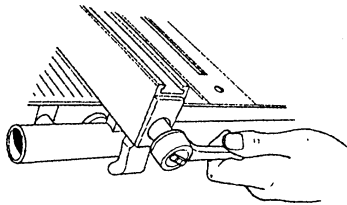

Figure B-92

ALIGN THE RIP FENCE PARALLEL WITH THE WORKTABLE

72. Place the miter gauge in the left slot of the worktable on the infeed side, as shown in Figure B-93.

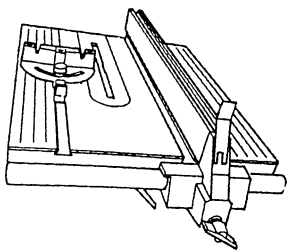

Figure B-93

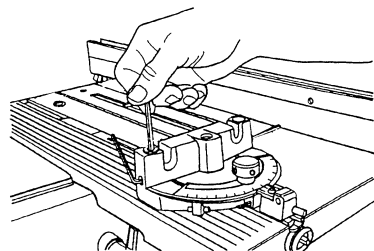

Figure B-94

73. Insert the long 5/32" Allen wrench through the miter gauge and secure it using the short 5/32" Allen wrench and a set screw borrowed from the tool rest, as seen in Figure B-94.

74. Move the rip fence toward the Allen wrench until it just touches it, as in Figure B-95.

75. Lock the base knob and handle on the base to secure both ends of the rip fence. See Figure B-95.

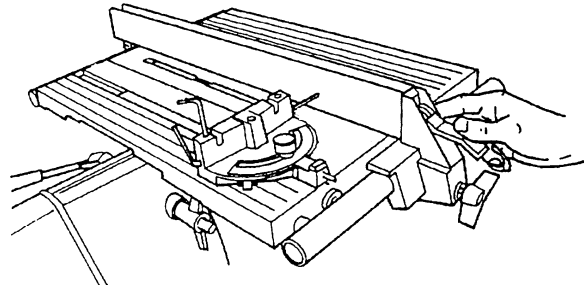

Figure B-95

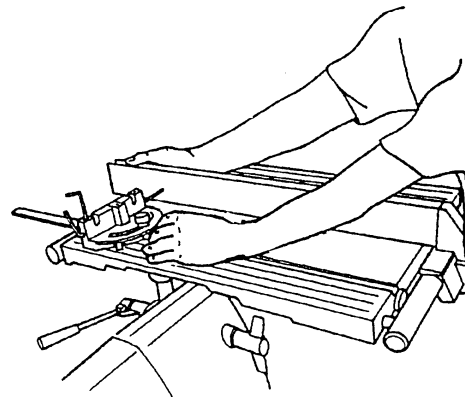

Figure B-96

76. Slide the miter gauge back and forth in the slot. See Figure B-96. The tip of the Allen wrench should keep in slight contact with the rip fence. Watch that you don't scratch the fence.

77. If it pulls away from or binds against the rip fence, the fence needs aligning. If so, do the following:

- a. Loosen the handle and base knob, remove the rip fence from the table and turn the fence upside down.

- b. Use a medium Phillips screwdriver to loosen the two screws (225) near the fence base, so they are just tight enough to require firm pressure to align the fence. See Figure B-97.

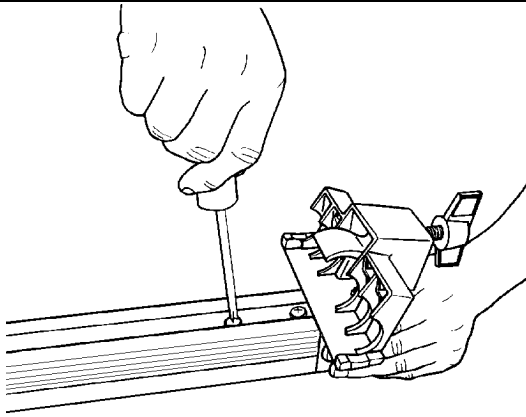

Figure B-97

- c. Return the rip fence to the worktable. Slide it toward the Allen wrench until it contacts the Allen wrench at the infeed end.
- d. Only tighten the base knob.
- e. Slide the miter gauge back and forth, adjusting the fence until the Allen wrench makes consistent contact along the entire length of the rip fence. Again, remember to not scratch the fence.
- f. When alignment is reached, lock the handle. Slide the miter gauge back and forth along the fence to double check that the fence did not move when you locked the handle.
- g. Reach under the table and use the medium Phillips screwdriver to tighten the screw closer to the base. See Figure B-98.

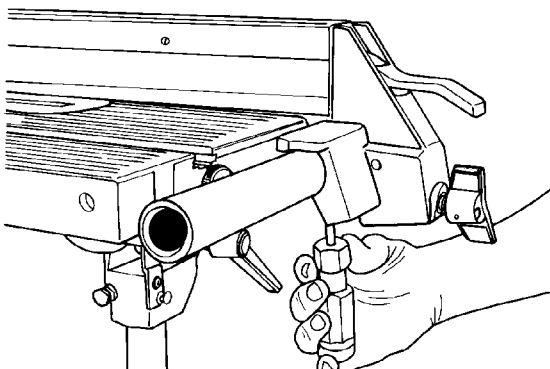

Figure B-98

- h. Carefully unlock the handle and the base knob on the base and lift the rip fence from the table.
- i. Tighten the other adjustment screw.

- j. To re-check the alignment, repeat Steps 74 through 79g. (It is very important to re-check the alignment!)

ALIGN THE EXTENSION TABLE

NOTE

These instructions are for aligning the extension table on the right side of the headstock. You can also follow these same procedures to align it to the left side of the headstock.

For most projects, align the extension table on the right side, since it can usually be used when placed on the left side. However, once the extension table is aligned on the right side, it cannot be transferred to the left side and still maintain precise alignment.

If you wish precise alignment on the left side, repeat the following instructions- but place the extension table on the left side in the headstock.

- 78. Mount the extension table in the Mark V's accessory base mount (on the right side) at a comfortable height, as shown in Figure B-99. Use a 1/2" wrench to loosen the bottom nuts holding the table base to the table approximately 1/4" from the table. This will allow you room for later adjustment.

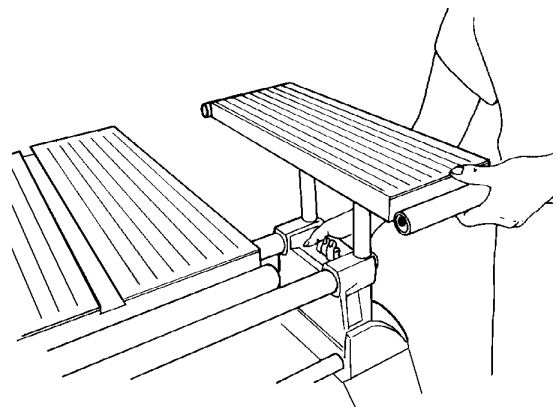

Figure B-99

- 79. The worktable should already be mounted in the carriage mount. Move the worktable next to the extension table and adjust it to about 1/4" above the extension table, as seen in Figure B-100.

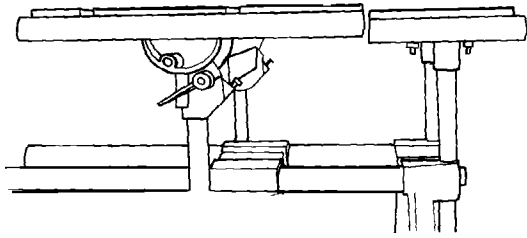

Figure B-100

80. Hold a straightedge against the **infeed edge** of both the worktable and extension table tubes, as in Figure B-101. Line up the extension table's infeed edge with the worktable's infeed edge. The elongated holes in the extension table's base permit you to slide the extension table forward and backward.

81. Hold a straightedge on the **infeed top surface** of both the worktable and the extension table, as shown in Figure B-102. As needed, adjust the top nuts located on the infeed side of the extension table, in order for the straightedge to be level across both the worktable and the extension table infeed sides. See Figure B-102a.

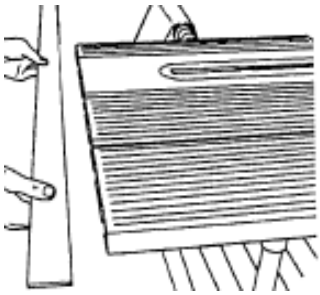

Figure B-101

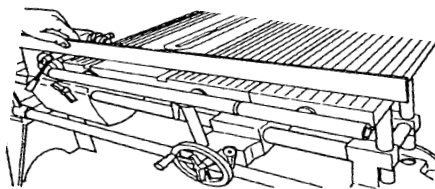

Figure B-102

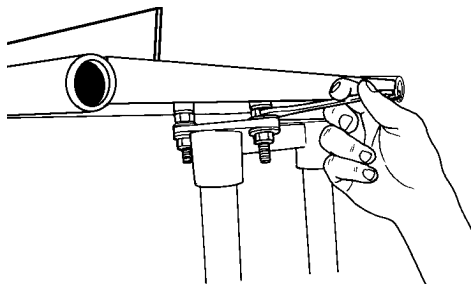

Figure B-102a

82. Hold the straightedge on the **outfeed top surface** of both the worktable and the extension table, as seen in Figure B-103. As needed, adjust the top nuts located on the outfeed side of the extension table, in order for the straightedge to be level across both the worktable and the extension table outfeed sides.

83. Double check the levelness at the infeed and outfeed sides of the table surfaces. All four top nuts (those nearest the table) used in leveling the extension table should be touching the base.

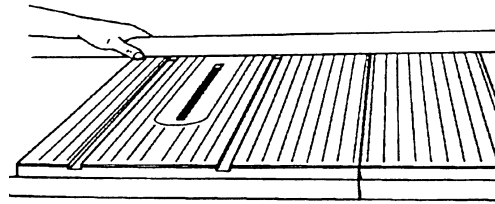

Figure B-103

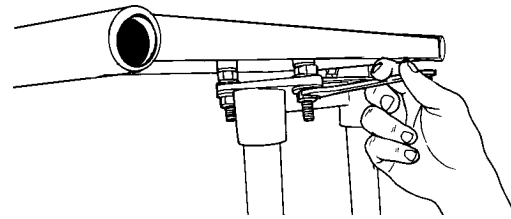

Figure 103a.

84. When the tables are aligned on three sides—**infeed side edge** (along the table tubes, as in Figure B-101), **infeed top surface** (as in Figure B-102), and **outfeed top surface** (as in Figure B-103) - securely tighten the bottom nut on each of the four studs, as seen in Figure 103a.



DO NOT overtighten the nuts. Tighten the nuts until they bottom out, then no more than 1/8 additional turn. Overtightening the nuts will stretch and damage the threads.

NOTE

If you move the Mark V to another location—especially one with an uneven floor—remember to re-check the extension table alignment.

ALIGN THE EXTENSION TABLE TUBES

85. Place the straightedge along the infeed-side tops of both the worktable and extension table tubes, as shown in Figure B-104.
86. If the extension table's tube is not aligned with the worktable's tube, use a $7/16$ " wrench to slightly loosen both keps nuts (248) attaching the tube to the extension table. Make the needed adjustments, then re-tighten the nuts. See Figure B-105.
87. Repeat Steps 85 and 86 for the extension table's tube located on the outfeed-side.

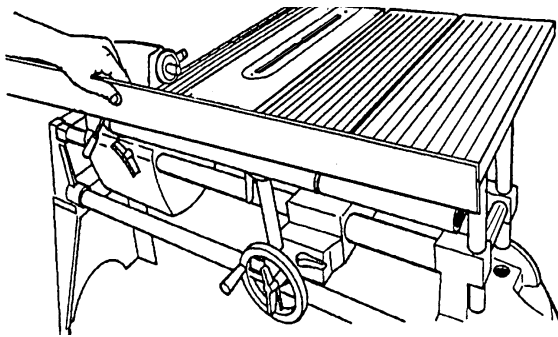

Figure B-104

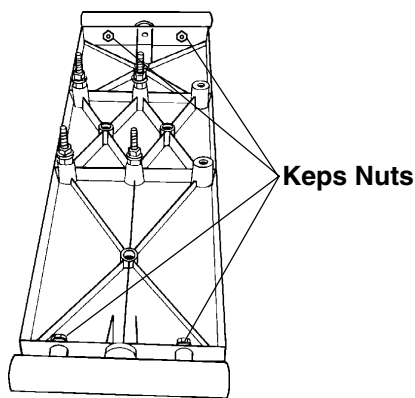

Figure B-105

MOUNT THE SAW GUARD

88. Loosen the accessory mount lock and remove the extension table. Loosen the table height lock and remove the worktable. Place the saw blade and arbor in the lower saw guard cover (204).

89. Fit the lower saw guard's clamp on the spindle quill (59). Line up the arbor set screw with the spindle knob's set screw (where the spindle flat is located). Use a $5/32$ " Allen wrench to tighten the arbor set screw, as shown in Figure B-106.

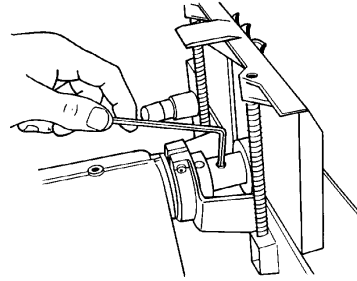

Figure B-106

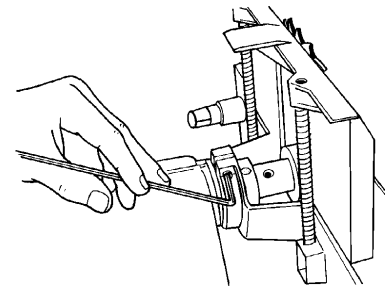

Figure B-107

90. Use the $5/32$ " Allen wrench to tighten the socket head screw (215) on the saw guard collar, as seen in Figure B-107.

INSTALL THE RIVING KNIFE

91. Loosen the guard lock knob (210) and insert the upper saw guard's riving knife (199) between the guard (213) and the lock plate (208), as demonstrated in Figure B-108.

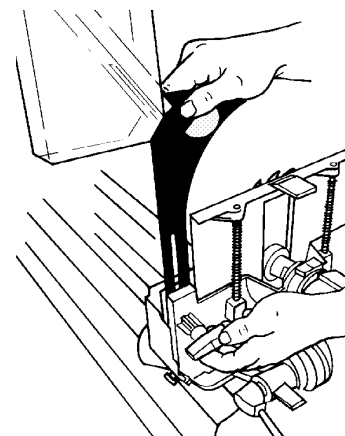

Figure B-108

92. Make sure the riving knife is fully seated between the guard and the lock plate, as in Figure B-109. The curved portion of the riving knife should be very close to the saw blade teeth (about 1/8"), as illustrated in Figure B-110. Tighten the guard lock knob (210). Look to see if the riving knife is centered with the saw blade, as shown in Figure B-111.

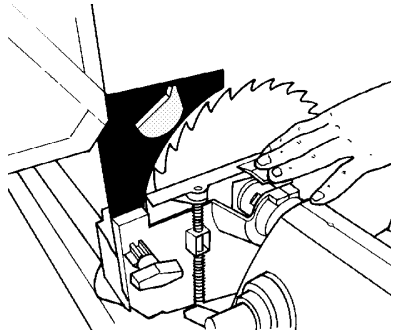

Figure B-109

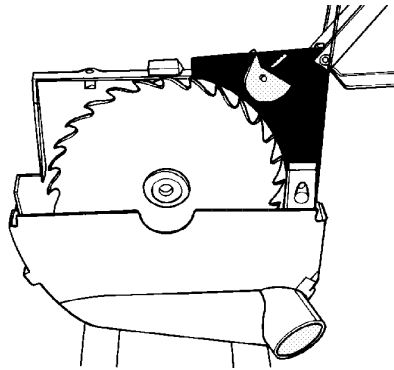

Figure B-110

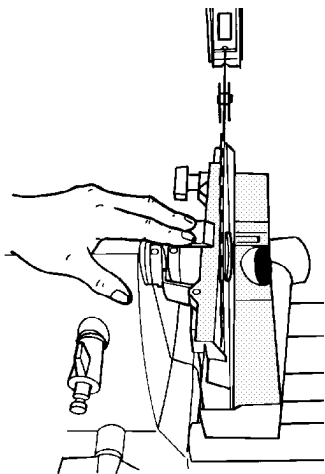

Figure B-111

93. If the riving knife is not centered with the saw blade, follow these steps:

- a. Notice which way the riving knife is not centered with the saw blade.
- b. Unclamp and remove the upper saw guard, then remove the saw blade and lower saw guard.

- c. Use a 5/32" Allen wrench to adjust the stop screw (211) located below the lower saw guard's collar, as seen in Figure B-112.
 - If the riving knife is to the **left** of the saw blade, back out the stop screw (counter-clockwise).
 - If the riving knife is to the **right** of the saw blade, screw in the stop screw (clockwise).
- d. Re-install the saw blade, lower saw guard and riving knife, according to Steps 88 through 92. If the riving knife is still not centered on the saw blade, repeat this Step 93.

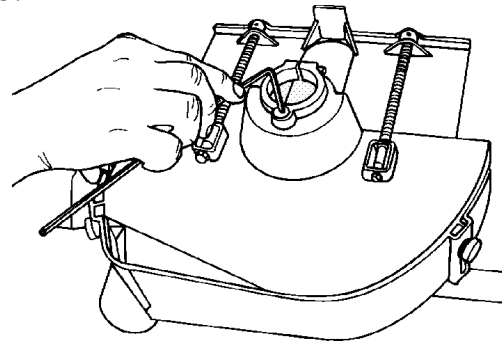

Figure B-112

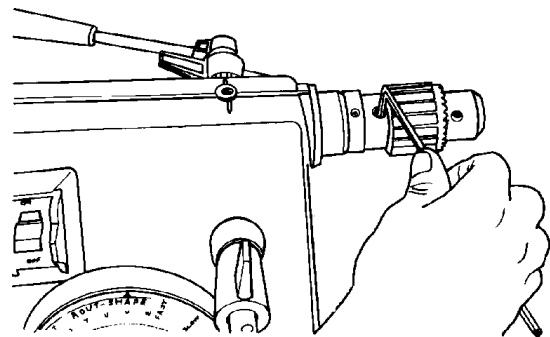

Figure B-113

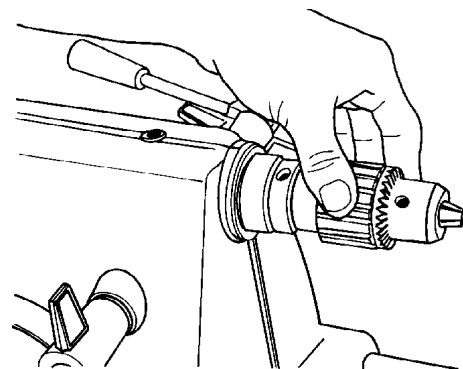

Figure B-114

ALIGN THE LATHE CENTERS

94. Remove the saw guards and the saw blade, then loosen the carriage and headstock locks. Move the headstock and carriage all the way to the right and lock them in place.
95. Mount the drill chuck on the spindle, as shown in Figure B-113. Completely close the chuck jaws, as in Figure B-114.
96. Mount the cup center into the tailstock's adjustable center, as seen in Figure B-115, then mount the tailstock into the base mount (right side). Tighten the mount lock.
97. Loosen the quill lock. Extend the quill (seen in Figure B-116), so the drill chuck almost touches the cup center point and the center point could fit into the chuck jaws.
98. If the center point does not "fit" into the chuck jaws, determine whether you need to adjust the cup center point horizontally and/or vertically. Then do the following:
 - a. To adjust the cup center point **horizontally**, loosen the set screw that locks the adjustable center, as seen in Figure B-117. Rotate the adjustable center as needed to line up the cup center with the drill chuck, then tighten the set screw.
 - b. To adjust the cup center point **vertically**, loosen the mount lock, then loosen the tailstock stop collars. Raise or lower the tailstock in the base mount until the cup center point vertically lines up with the drill chuck, then tighten the mount lock. Press the stop collars down firmly against the base mount and tighten the collar set screws, as shown in Figure B-118.

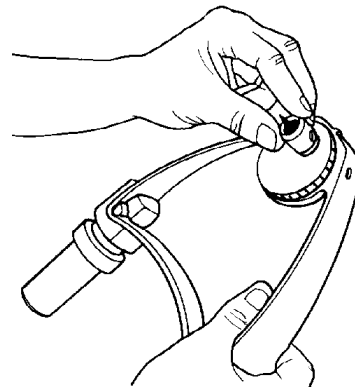

Figure B-115

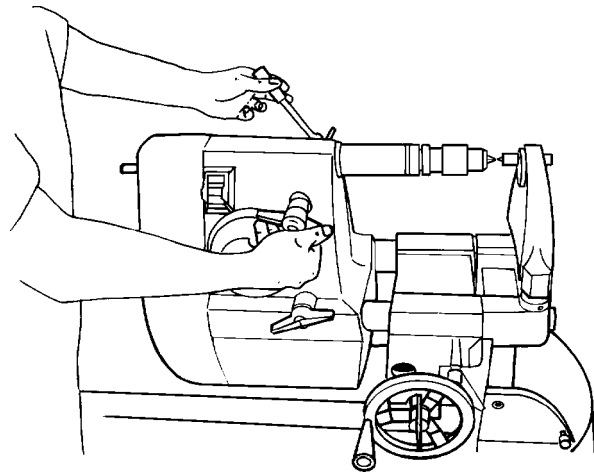

Figure B-116

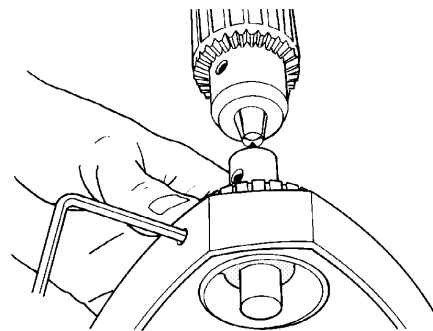

Figure B-117

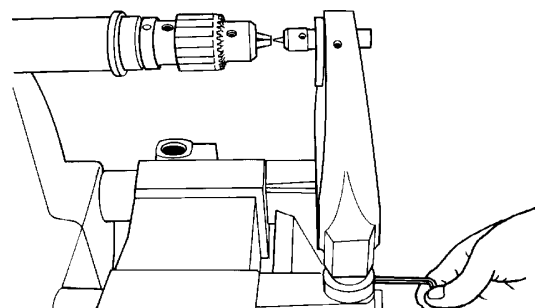

Figure B-118

NOTES